



**HYDRAULIK**



**SOLUTIONS**  
in motion



**DRY UNIT**

**INSTALLATION GUIDE**

# Product presentation

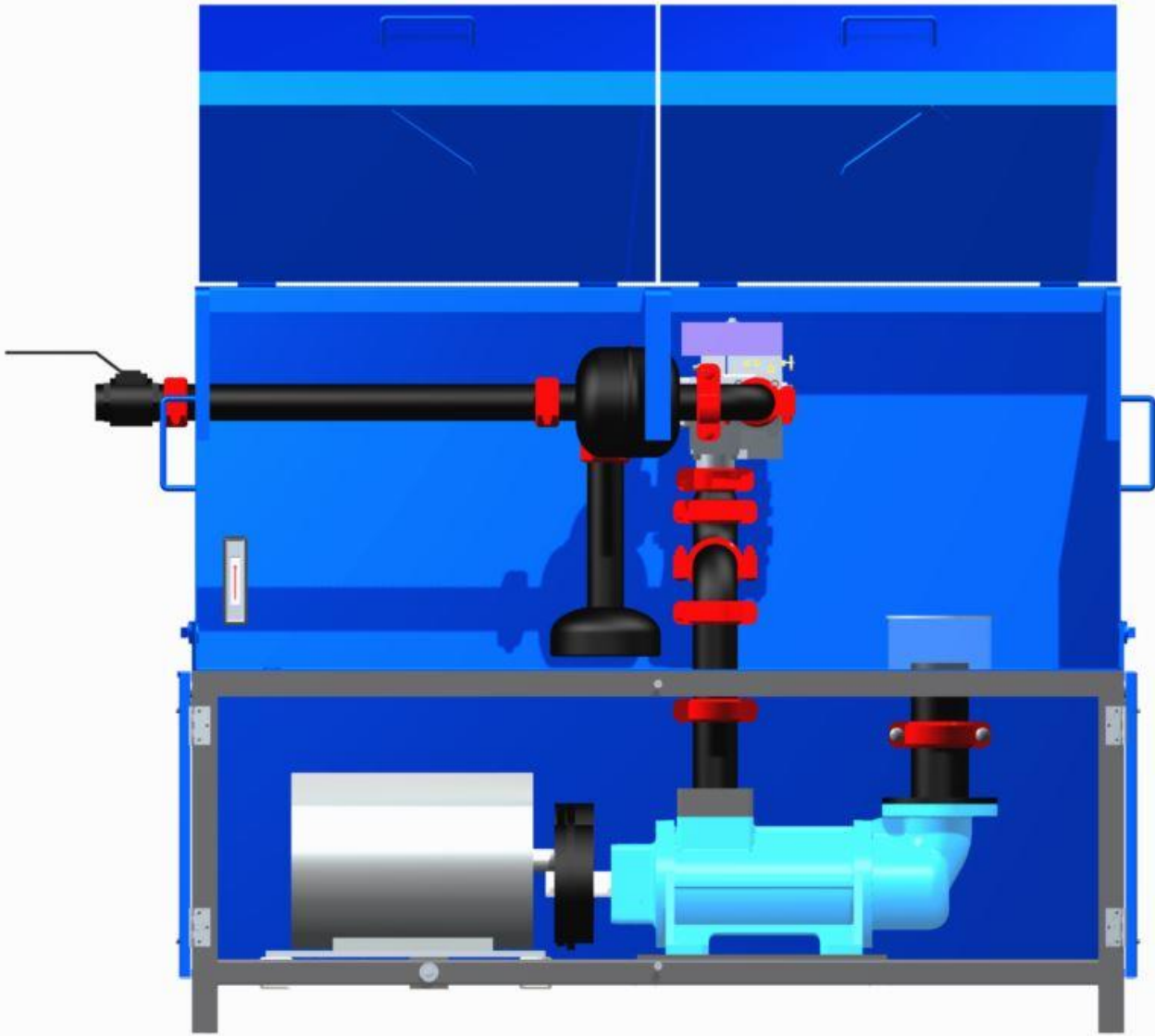

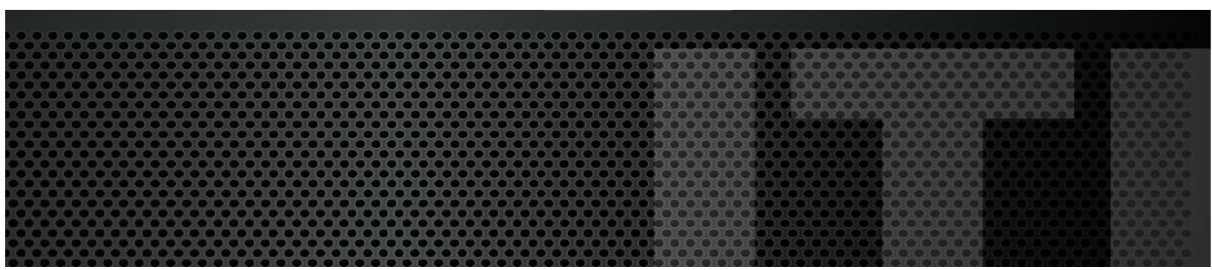

## Table of **contents**

Product presentation.....	2
Technical drawing.....	4
Adjustment .....	5
Options .....	6
Warranty policy.....	7-8

# Technical drawing

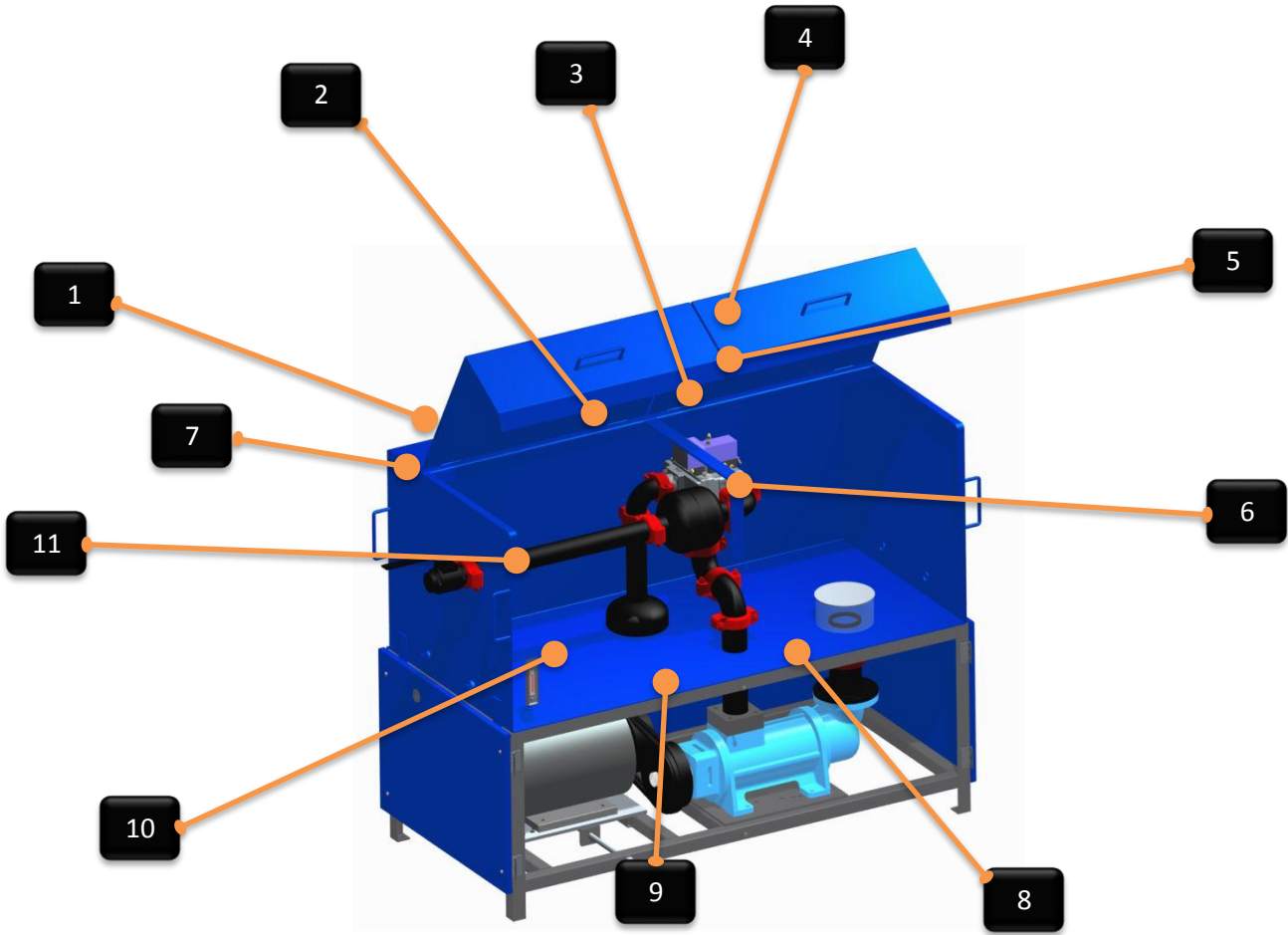



#	Components	Materials
1	Ball Valve	Steel
2	Exit line	Steel
3	Muffler	Steel
4	Coil	Steel
5	Valve	Steel
6	Pressure Line	Steel

#	Components	Materials
7	Connection box	Steel
8	Pump	Steel
9	V-Belt	Rubber
10	Motor	Steel
11	Oil Level	Plastic

## Adjustement

Maxton supplies the great majority of all the valves used in our power units. For updates or further information, please visit their website: <http://maxtonvalve.com/>

We also use some Blain valves. Here is the link to their website:  
<http://www.blain.de/soupape-pour-ascenseur/?lang=fr>

One of our other suppliers is EECO. You can go to their website here:  
<https://www.elevatorequipment.com/>

# Options

## Optional equipment

- Twin Configuration with Two Pumps and Two Motors
- Oil Line Output Position
- Aluminium Tank
- Tank Color
- Thermistor
- Tank Shutoff Valve
- Muffler Extra
- Oil Heater (120 Volts or 240 Volts)
- Prevision Oil Cooler
- Oil Cooler
- Drip Pan
- Pressure Negative Switch
- Ball Valve Extra
- Insulation Coupling
- Adjustable Thermostat
- Clear Hose Oil Level
- Line Strainer
- Seismic Tie Down
- Low Level Switch
- Anti-Vibration Pad
- Controller Mount



# Warranty policy

## GUARANTEE

1. ITI HYDRAULIK warrants to the original purchaser that this Product is free from any defects in materials or workmanship and agrees to repair or replace, in its sole discretion, any Product found to be defective during the period of **one year** from the date of delivery to the customer.
2. This warranty is only given to the original purchaser and comes into force on the delivery date of the Product.
3. The delivery date is the date of assumption of responsibility of the Product, ascertained by the bill of lading of the carrier.
4. Any part of this Product deemed, after reasonable evaluation by ITI HYDRAULIK, to be defective in workmanship or materials, will be repaired or replaced, free of charge for parts and labor, by ITI HYDRAULIK.

## LIMITATION OF WARRANTY

5. This quality guarantee covers any defect in the manufacture or materials of the sold Product provided that:
  - (a) the Product is used for the purpose for which it is designed, intended and recommended by ITI HYDRAULIK;
  - (b) the Product has been installed and maintained by qualified personnel; and
  - (c) the maintenance recommended by ITI HYDRAULIK has been carried out by qualified personnel.
6. This warranty does not cover claims for damages, direct or indirect, for loss of time, or caused by a Product modification, Product tampering or Product adjustment made by or for the Buyer and not previously approved by ITI HYDRAULIK.
7. This warranty does not cover Product that has been damaged through abuse, neglected, lack of maintenance or failure to maintain the Product pursuant to the instructions in the user manual provided by ITI HYDRAULIK.
8. This warranty does not cover repairs necessitated by normal wear and tear of the Product or the use of unapproved parts and accessories with the Product or that are harmful to its proper functioning, performance or durability. In addition, this warranty excludes: consumable materials – hydraulic fluids, etc.
9. This warranty does not cover damage caused during transport, installation, maintenance or return of the Product. The Buyer shall promptly notify ITI HYDRAULIK in writing sent by mail, fax or registered mail when a defect is discovered, with a detailed explanation of the alleged defects. ITI HYDRAULIK will not assume and therefore will not pay any amount related to the elements mentioned above.
10. This warranty can not be relinquished, transferred or assigned to a third party; it is granted exclusively to the original purchaser of the Product. In the event that the Product is sold, transferred or otherwise disposed of, this warranty becomes void immediately for all legal purposes.

## SUITABILITY OF THE PRODUCT

11. ITI HYDRAULIK complies with the manufacturing standards applicable to the Product sold. States and localities are governed by codes and regulations pertaining to construction, installation and use standards, which may differ from one region to another. ITI HYDRAULIK cannot be held responsible for the conformity of the Product with the application of these codes, standards, regulations; the Buyer is solely and exclusively responsible for this compliance before the confirmation of the order.

## STORAGE OF THE PRODUCT

12. Storage of ITI HYDRAULIK products is not recommended for a period longer than 1 month; a horizontal position of the Product for a period of time greater than one month, may cause oil leakage. Any temporary storage requires a dry place, protected from theft, moisture, extreme heat and cold. Damage and defects caused by improper storage, stacking or handling are not covered by this warranty.

## RETURNS OF MERCHANDISE

13. Any request to return the Product must be authorized prior to shipment by ITI HYDRAULIK Technical Services. Following an authorization from ITI HYDRAULIK, a return number is assigned and must be indicated on the outer packaging of the Product return packaging. The same packing criteria as at the original packing receipt must be utilized. The customer is responsible for transporting the return of the Product to the specified ITI HYDRAULIK factory. A Product found to be defective after inspection by ITI HYDRAULIK may, in our sole discretion, be repaired or replaced at no charge. A credit request for any product return must be authorized by ITI HYDRAULIK and is subject to a 35% restocking fee, plus initial shipping costs.

## TECHNICAL SERVICE

14. ITI HYDRAULIK provides free installation manuals on its website and technical assistance on its Products. This information is intended for people with knowledge and skills in this area who will use it at their own risk. ITI HYDRAULIK assumes no liability for damage caused by anyone using these manuals.

## PRICES OF PRODUCTS

15. Product prices are subject to change without notice.

## FORCE MAJEURE

16. From the date of delivery, the buyer assumes all liability and costs inherent to the Product. ITI HYDRAULIK shall not be considered in default in the performance of its obligations hereunder if such performance is delayed, withheld or prevented as a result of a fortuitous event or force majeure. Force majeure is any cause that ITI HYDRAULIK could not reasonably have foreseen and against which it could not have protected itself. Force majeure includes, but is not limited to, any fortuitous event, injury, illness, accident, death, destruction of property, use of the Product sold, natural disaster, strike, partial or complete stoppage of work, lockout, fire, riot, intervention by civil or military authorities, acquiescence with the regulations or orders of any governmental authority and warfare (declared or not).





## PRIORITY CLIENT

Since 20 years, the ITI engineers had access to tools and to state-of-the-art formations of the industry. It is this continues training that allows us to provide you with quality products that will meet your needs. Furthermore, we are the leaders regarding delivery deadlines.



3611 ROUTE 346, SAINTE-JULIENNE (QUÉBEC) J0K 2T0

TELEPHONE : 450-831-3229 | FAX : 450-831-2219 | TOLL FREE : 1-800-953-3229 | E-MAIL : [INFO@ITIHYDRAULIK.COM](mailto:INFO@ITIHYDRAULIK.COM)